

LIMITS TO USE

Max gate-leaf width (m/ft)	1,0m	1,2m	1,8m
Max gate-leaf weight (Kg/lb)	400kg	300kg	200kg

GATE-LEAF OPENING ARC (°)	A	B	C
90°	155	155	90
130°	140	125	60

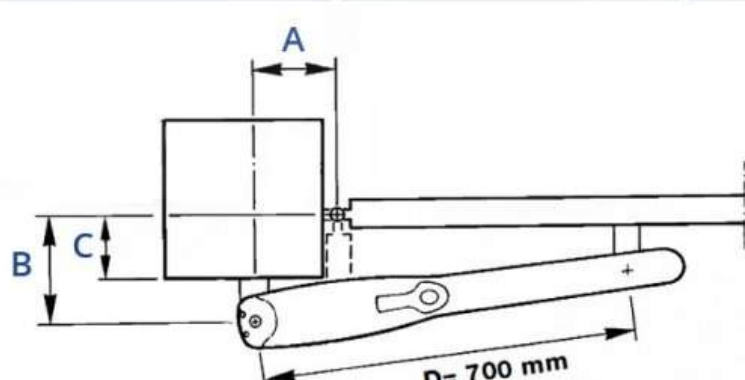

BASIC INFORMATION

Motor power supply	230V
Leaf maximum width	1.8 m
Leaf maximum weight	400 kg
D-Dimension	15 cm
Motor type	electronmechanical

MOTOR TECHNICAL DATA

Power Supply	230/230 V
Current draw	0.5 A
Max Power	120 W
Duty cycle	30 %
Traction force	1500 Nm
Motor thermal protection	140 °C
Opening time (90°)	0.016 m/s
Maximum opening angle	130°
Operating temperature	-20° - + 50°C
Protection rating	IP 44
Self-locking	yes
Limit switches for opening	yes
Limit switches for closing	optional*
Encoder	no

BASIC CONTROL BOARD FUNCTIONS

Second line of photocells	yes
Pedestrian passage function	yes
Electrolock connection	yes
Amperometric sensor	yes
Running time adjustment	no
Force adjustment	yes
Pre-Flashing of the warning light	yes
Automatic closing	yes
Soft-stop, soft-start	no/no